



2022

Ransomware Trends Report

In January 2022, an independent research firm completed a survey of **1,000** unbiased IT leaders about the impact ransomware had within their environments, as well as their remediation methods and future-facing strategies. Respondents consisted of one of four personas: CISOs, security professionals, backup administrators and IT operations. These personas represented organizations of all sizes from 16 different countries across APJ, EMEA and the Americas, including **500** from the Americas.

Ransomware pervasiveness

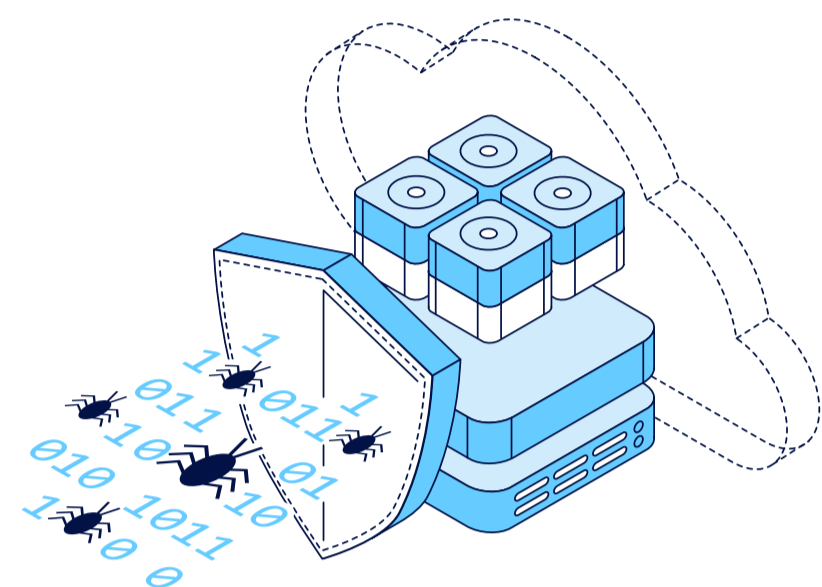

95%

of ransomware attacks attempted to infect backup repositories, and **71%** of those attempts were successful

44%

of production data was successfully encrypted – and of that, only **67%** of data was recoverable

Ransom ≠ remediation

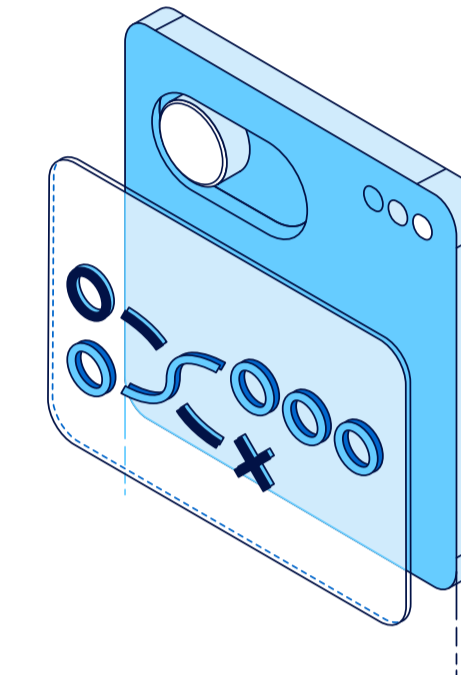

19%

of organizations were able to recover without paying the ransom

31%

of organizations who paid the ransom still could not recover their data

Technologies for survival

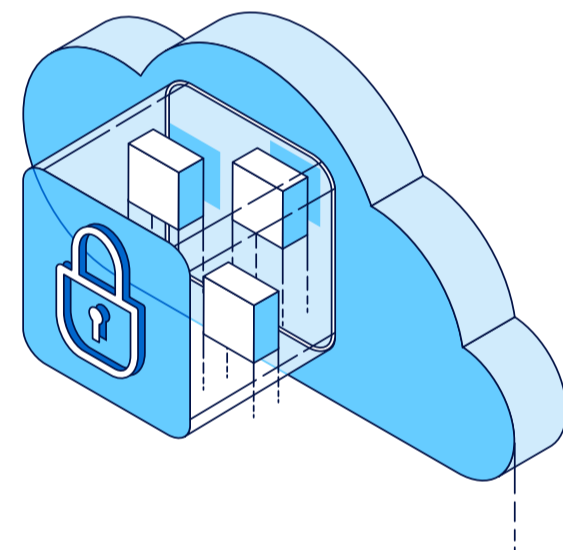

84%

of organizations rely on backup logs or media readability to assure recoverability, meaning only **16%** routinely test by restoring and testing functionality

43%

of organizations first restored to an isolated sandbox before recovering data after a ransomware attack

Organizational alignment

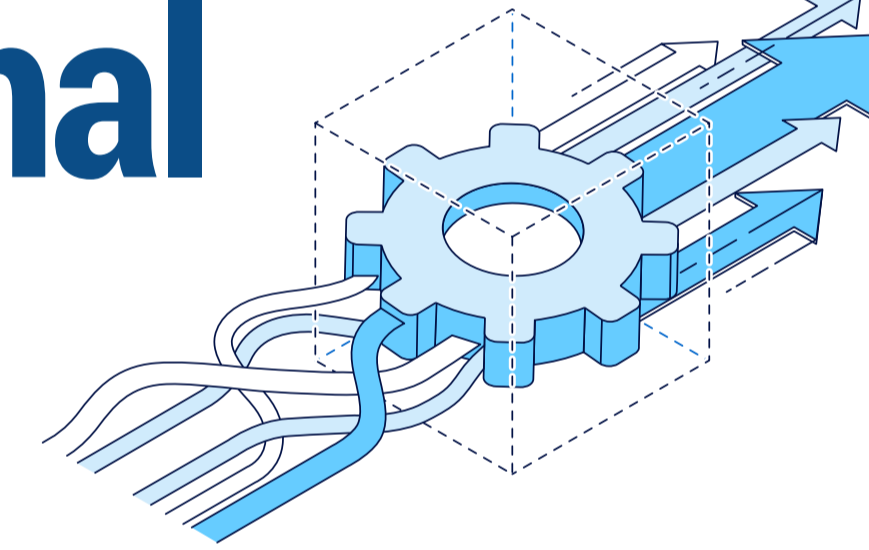

53%

of organizations believe a significant or complete overhaul is needed between backup and cybersecurity

38%

of cyberteam's ransomware playbook includes verifications or assured-cleanliness mandates

ooo



Secure Backup is your last line of Defense

Ransomware is a disaster that costs businesses nearly two million dollars (US) per incident. At Veeam® we believe secure backup is your last line of defense against ransomware. Our software is secure by design eliminating lock-in into proprietary hardware to work with your existing architecture, both on-prem and in the cloud because having a reliable backup can be the difference between downtime, data loss and paying a costly ransom.

